

Plane installation documentation in standard configuration in millimeters

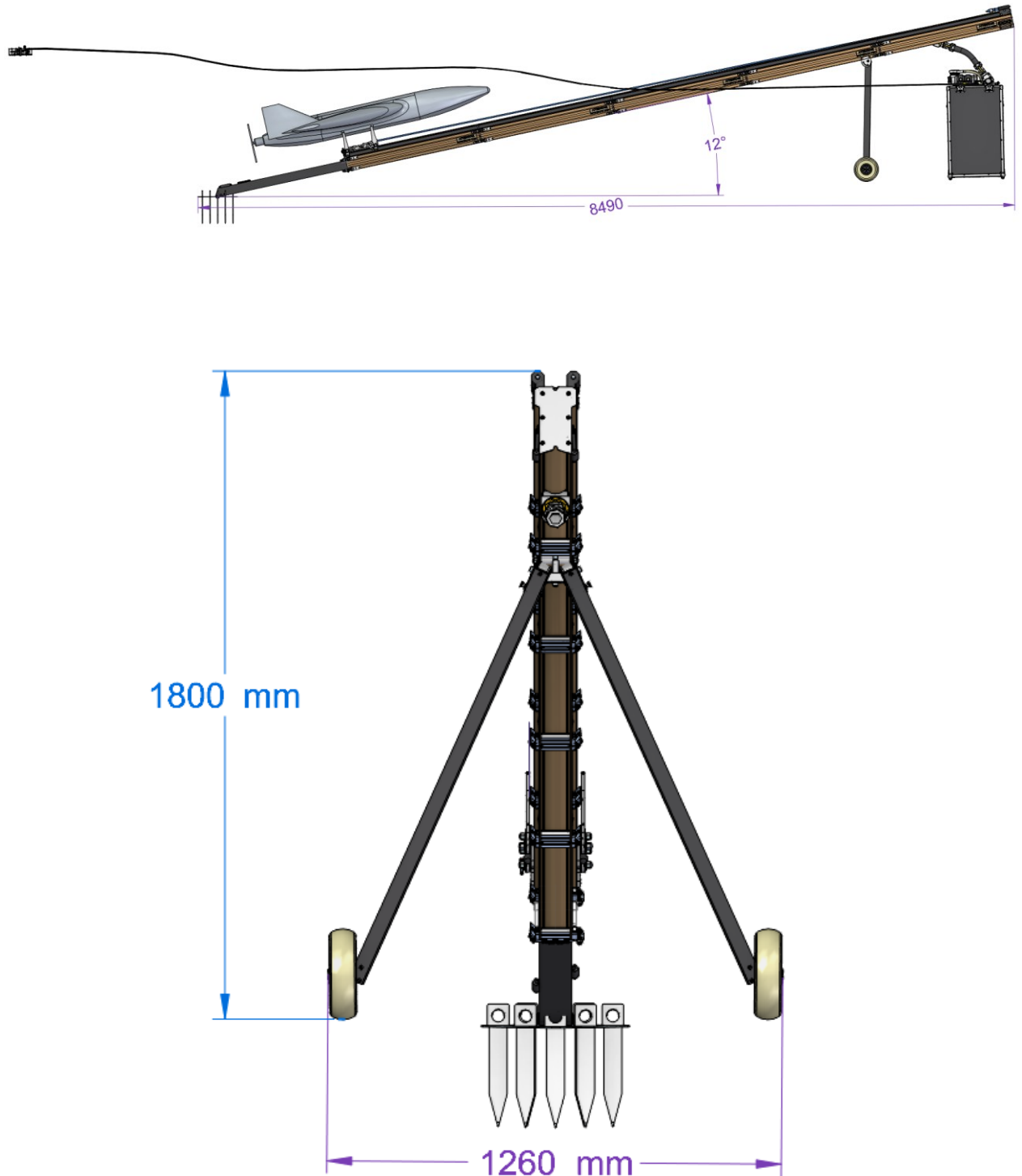

Figure 10-1 Overall dimensions when the PL-80 is assembled.

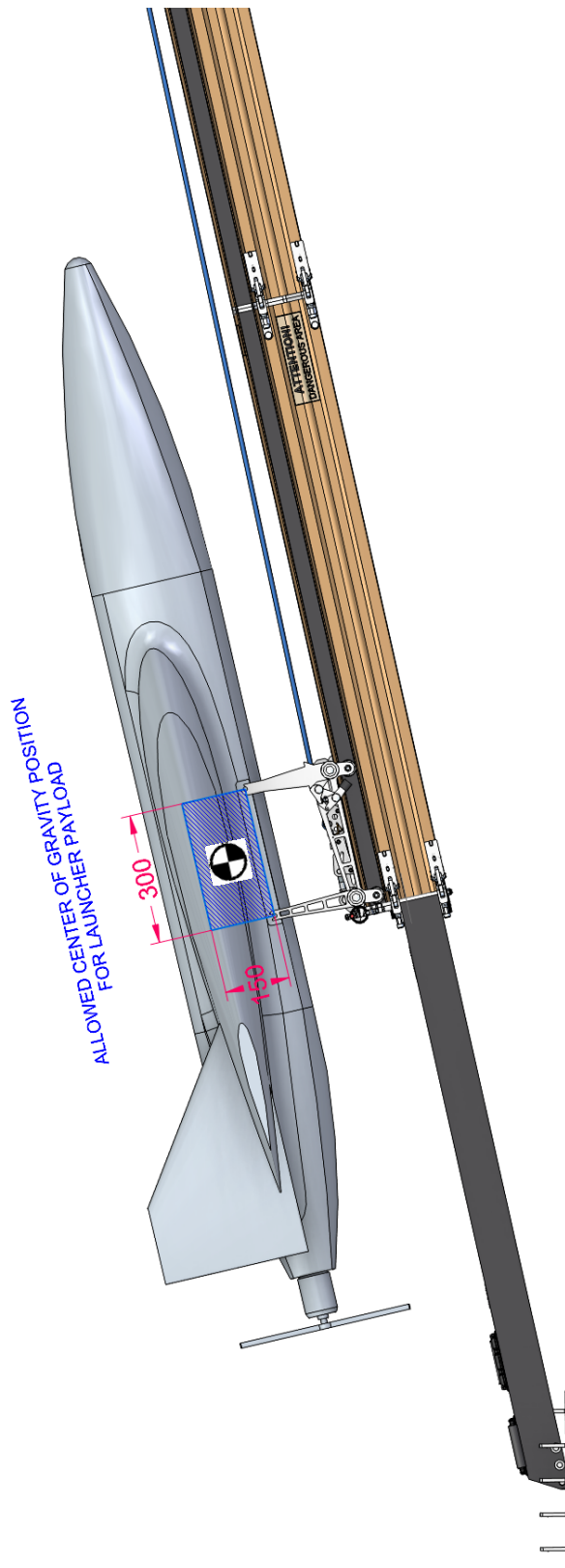

Figure 10-2 Allowed positions of the center of gravity relative to the carriage.

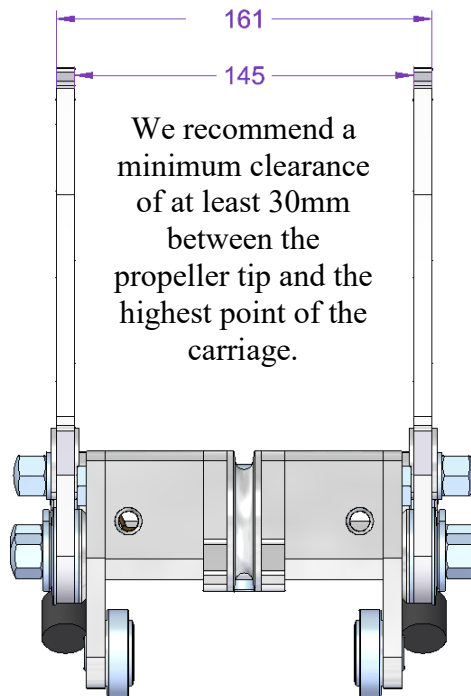
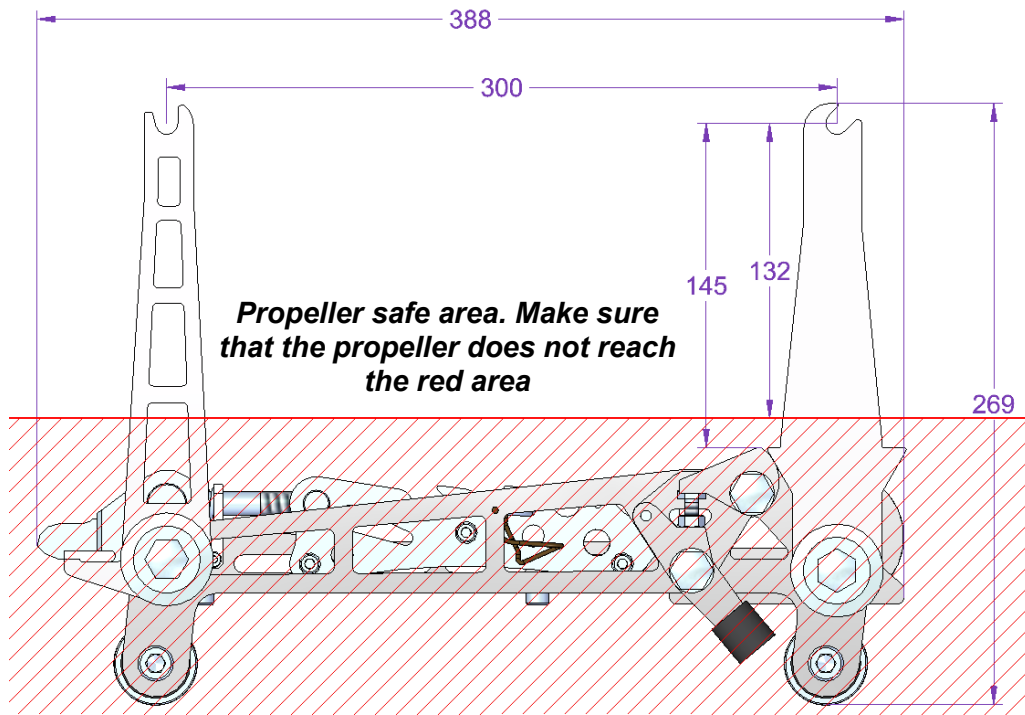

Figure 10-3 Standard carriage I dimensions

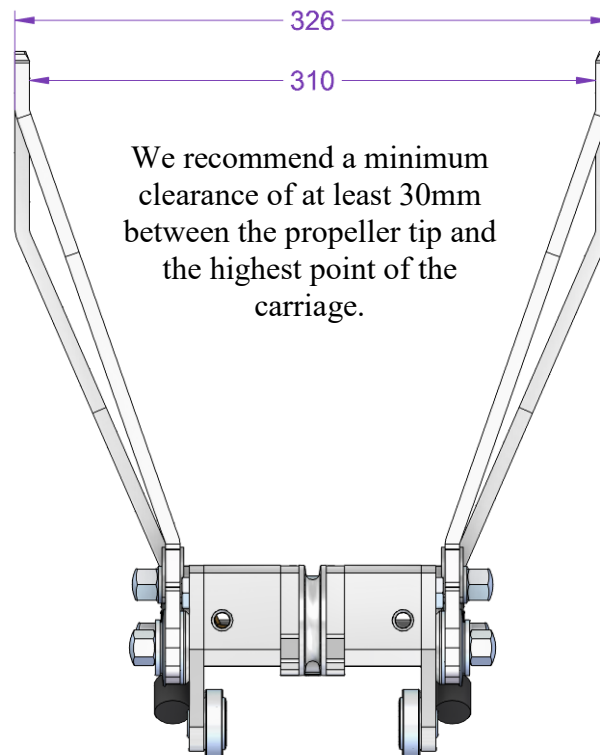
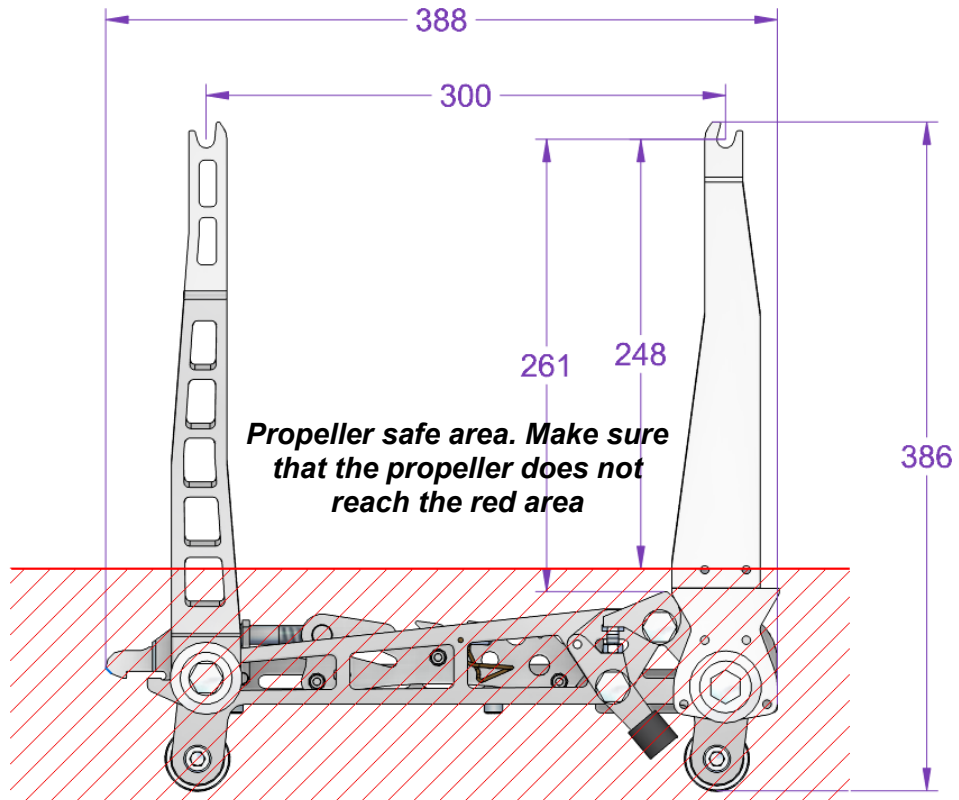

Figure 10-4 Standard carriage II dimensions.